

Trademarks

Panasonic® is a registered trademark of Matsushita Electric Industrial Co., Ltd.

Overview

Table 1: Product Descriptions

Model Number	Description
ISW-EN1233D	Double-button, necklace pendant transmitter
ISW-EN1233S	Single-button, necklace pendant transmitter
ISW-EN1235D	Double-button, belt-clip pendant transmitter
ISW-EN1235S	Single-button, belt-clip pendant transmitter

1.0 Open the Transmitter Housing

Insert a small, flat-bladed screwdriver into the housing notch, and gently pry the housing apart.

Figure 1: Transmitter Housing (ISW-EN1233D shown)

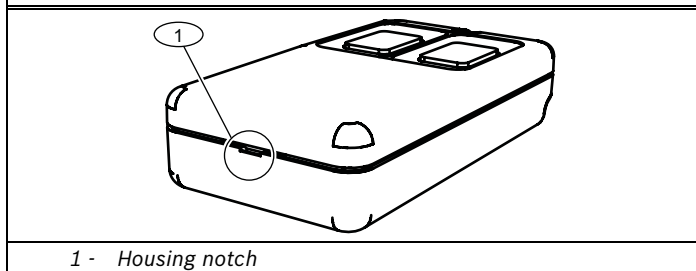

Refer to Figure 2 for component locations.

Figure 2: Transmitter Components

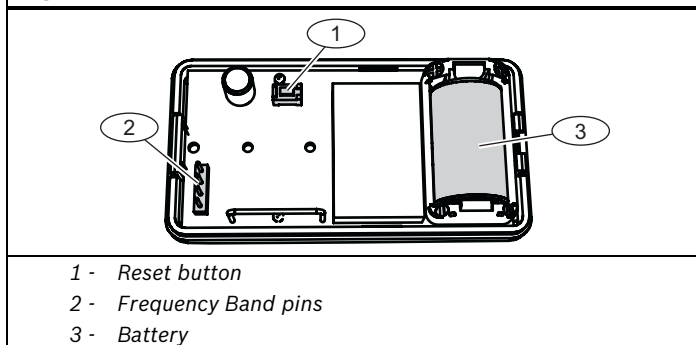

2.0 Select the Frequency Band

Select the appropriate frequency band for your geographic area. Refer to Figure 3.

i If you change the transmitter's frequency band setting after initial installation, press the Reset button for the new setting to take effect.

Figure 3: Frequency Band Settings

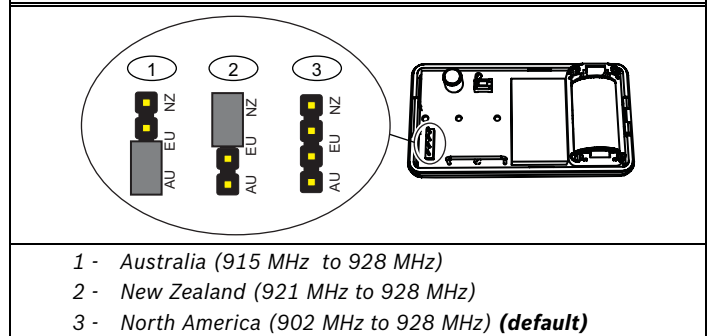

3.0 Install the Battery

1. Install the battery in the location shown in Figure 2.
2. Press the Reset button.

4.0 Register the Transmitter

You must register the transmitter with the system in order for the transmitter to be monitored and supervised. When the transmitter is supervised, it sends a check-in message to the serial receiver or network coordinator every three minutes. Each transmitter has a unique factory-programmed identification number. Refer to the receiver's documentation for details on registering a transmitter. When prompted by the receiver to reset the transmitter, press the Reset button on the transmitter. Refer to Figure 2.

i Test the transmitter after it is registered with the system. To test the transmitter, activate each of the conditions and ensure an appropriate response.

5.0 Using the Transmitter

5.1 Using the Pendant Chain

Always use the chain included with the ISW-EN1233D or ISW-EN1233S. Substituting stronger cords or chains can result in injury to the wearer.

5.2 Converting the Pendant Transmitter Belt Clip

To convert the pendant transmitter belt clip to a belt loop on the ISW-EN1235D or ISW-EN1235S, secure the bottom of the belt clip to the housing with the included belt loop screw.

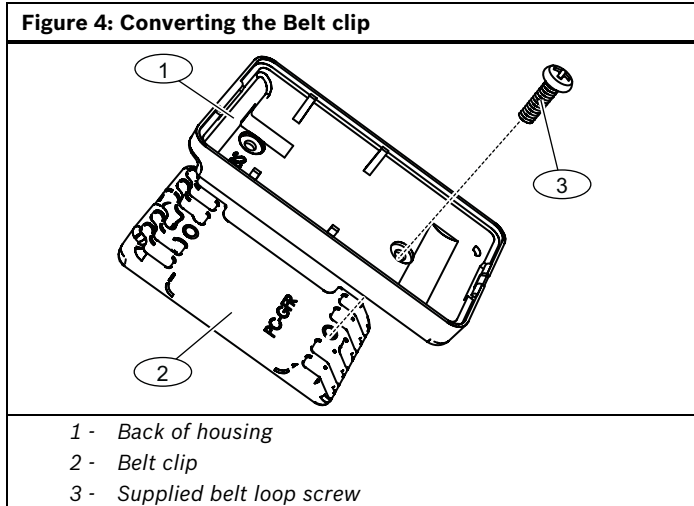

5.3 Operate the Pendant Transmitter

To activate or test the single-button transmitters, press and hold the button. To activate or test the double-button transmitters, press and hold both buttons.

Alarm signals are sent multiple times and are indicated by the blinking transmission LED. When the buttons are released, the transmitter sends an alarm restoral signal

6.0 Specifications

Power Requirement:	3 VDC at 60 mA
Operating Temperature:	0°C to +60°C (+32°F to +140°F)
Relative Humidity:	Up to 90% (non-condensing)
Battery Type:	Panasonic® CR2, Sanyo CR2 or equivalent
Typical Battery Life:	3 to 5 years
Compatible Receivers:	ISW-EN4204R, ISW-EN4216R, and ISW-EN7280

